

Guided Reading: Chapter 25

1. Why are *sedimentary rocks* (and not igneous or metamorphic rocks) the richest source of fossils? (p.484)
When aquatic and life-forms and terrestrial organisms are swept into the sea and swamps and die, they settle along the sediments and a TINY FRACTION of them are then preserved as fossils. The formation of igneous and metamorphic rocks (high pressure and/or heat) destroys all living remains.
2. Paleontologists use a variety of methods to date fossils. Briefly describe two of the most common methods of dating fossils listed below: (p.486)
 - (a) **Relative Dating** - the process of determining if one rock or geologic event is older or younger than another, without knowing their specific ages but by comparing them to different strata (rock layer)
 - (b) **Absolute Dating** - does not mean errorless dating, but only that age of a rock or geological event is given in years instead of *before* and *after*
3. Why is the fossil record incomplete? (p.488)
The fossil record is incomplete due to the many circumstances that must take place for an organism to become fossilized which make the fossil record slanted in favor of species that existed for long periods of time.
4. What was *Pangaea* and how long ago did it break up causing geographic isolation of colossal proportions? (p.489-490)
Pangea (*all land*) was a supercontinent single land mass created 250 million years ago when plate movements brought all of the land masses together. Pangea broke up 180 million years ago.
5. What is *systematics*? (p.492)
Systematics is the study of biological diversity in an evolutionary context.
6. What is *taxonomy*? (p.492)
Taxonomy is the naming and classification of species and groups of species

7. Every organism on Earth may be referred to by a unique **binomial**, or a two-part name. These are in Latin, or latinized. What is your binomial? What does it mean? (p.493)

Humans binomial name is ***Homo sapien*** which means "wise man."
 genus species

8. What are the two components of every binomial? (p.493)

The two components of every binomial is the genus and species name.

9. What is your COMPLETE scientific name?

Eukarya Animalia Chordata Mammalia Primate Hominidae *Homo sapien*
 (vertebrates)

10. Taxonomy uses hierarchical categories that nest within each other, like Russian dolls. The figure below shows the categories, each called a *taxon*. Label each taxonomic category, in the boxes, and then give the one that applies exclusively to this panther to the side of each box. (p.493)

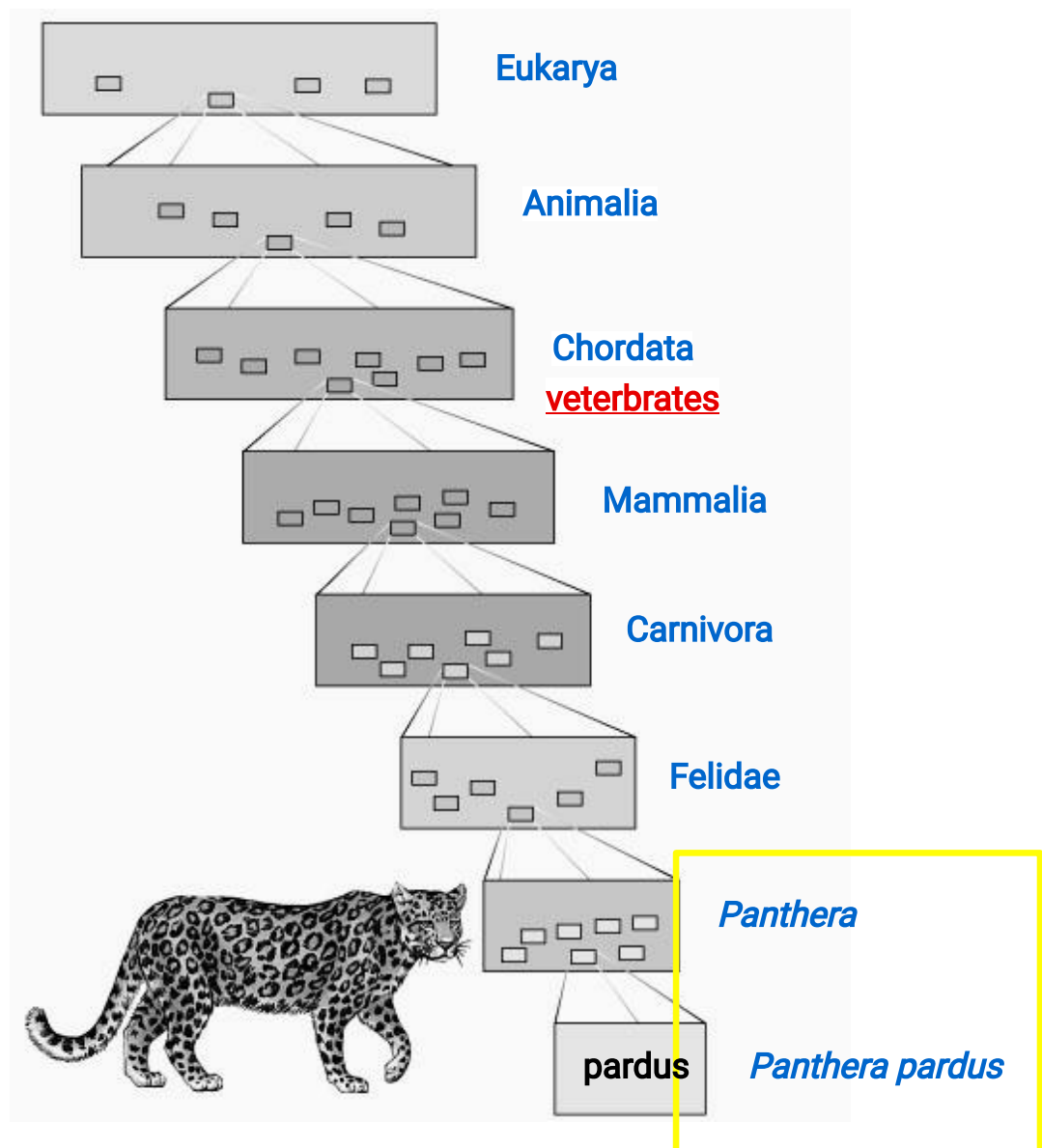

11. You will notice that the most general category, *domain*, the one that encompasses the most organisms, is shown at the bottom of the figure. As you move up in the figure, the organisms show greater and greater degrees of relatedness. You are expected to memorize these taxonomic categories in order! Most students use a mnemonic device linked to the first letter of each taxon to remember them.

Make up your own, or try mine:

DKPCOFGS or **Dear King Phillip Comes Over For Good Strawberries**
 (You may choose to have King Phillip come over for something else—whatever you can remember best!)

12. So, which are more closely related, organisms in the same phylum, or those in the same order?

Organisms in the same ORDER are more closely related.

13. Below is a *phylogenetic tree*. Recall that branch points represent common ancestors of the two lineages beyond the branch or *node*. Circle the common ancestor of striped skunks and European otters and label it as **A**. Circle the common ancestor of domestic dogs and wolves and label it as **B**. Which 2 species are more related? Explain your answer.

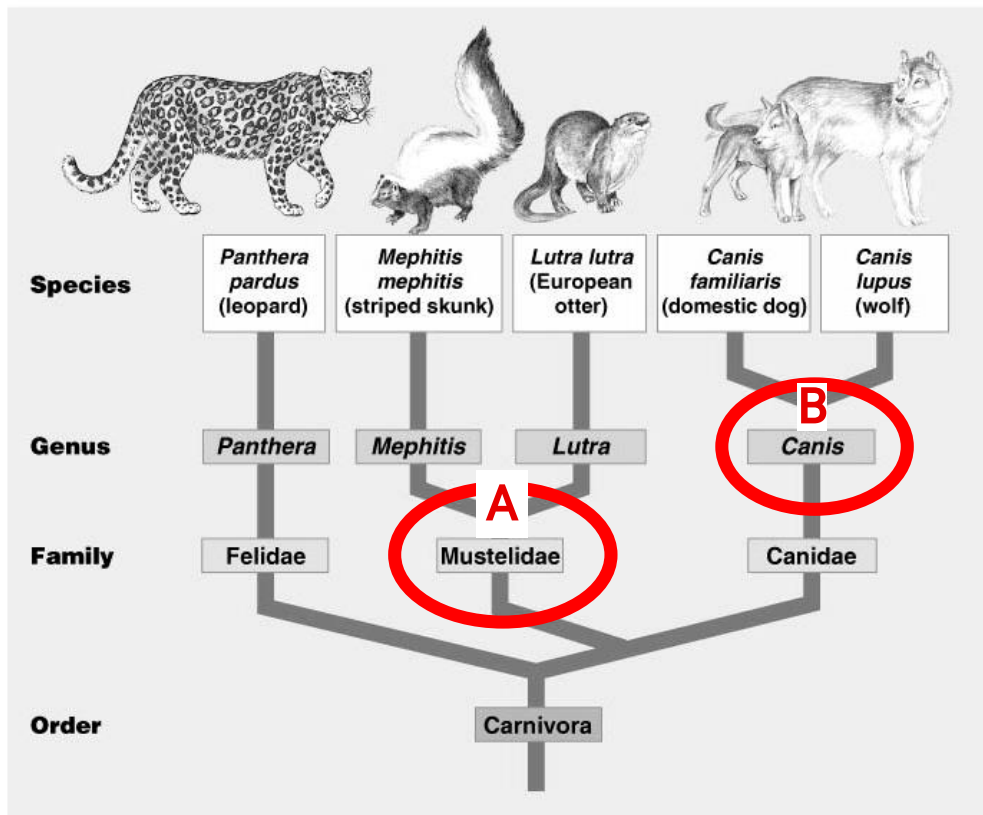

The domestic dog and wolf are more related because they each belong to the same genus.

Let's look back at an idea from Chapter 22. This idea is repeated in this chapter.

Study Tip:

Homologous structures show evidence of relatedness.

Example: whale fin, bat wing

Analogous structures are similar solutions to similar problems but do *not* indicate close relatedness.

Example: bird wing, butterfly wing

14. *Molecular systematics* is a valuable tool used today to sort *homology* from *analogy*. What is it? (p.497-498)

Molecular systematics is the comparison of genes and gene products (proteins) of organisms. At the molecular level, the evolutionary divergence of species parallels the accumulation of differences in their genomes. Molecular systematics makes it possible to assess phylogenetic relationships that cannot be measured by comparative anatomy and other nonmolecular methods.

15. Below are three *cladograms*. What is a *cladogram*? What is a *clade*? (p.494)

A cladogram is a phylogenetic diagram based on cladistics or a branching diagram showing the cladistic relationship between a number of species. A clade is an evolutionary branch in a cladogram or a group of organisms believed to have evolved from a common ancestor.

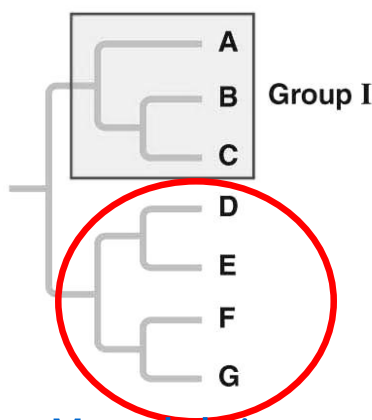

(a) Monophyletic

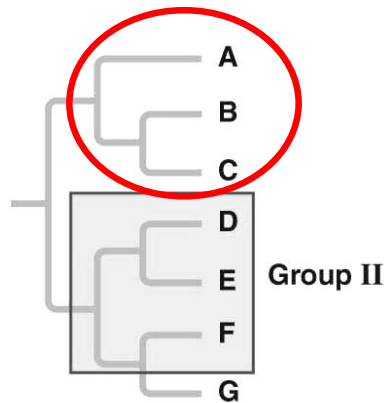

(b) Paraphyletic

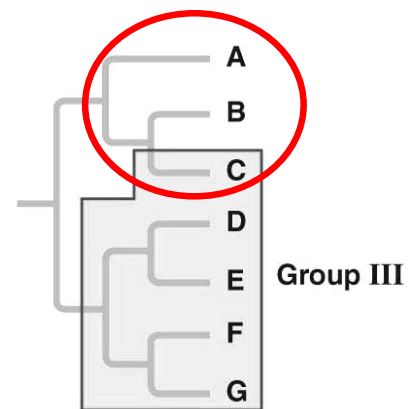

(c) Polyphyletic

16. In the space below each cladogram, identify which is a *monophyletic*, *paraphyletic*, and *polyphyletic* group. (p.495)

17. Circle a *clade* that is not highlighted below.

18. Why is Group I *monophyletic*? (p.495)

Group I is monophyletic because it consists of an ancestral species and all of its descendants or from a "single tribe."

19. Explain why Group II is *paraphyletic*. (p.495)

Group II is paraphyletic because it consists of a common ancestor and some, but not ALL of that ancestor's descendants (species G is not included).

20. What is a *polyphyletic group*? (p.495)

A polyphyletic group lacks a common ancestor that would unite the species as a monophyletic group or consists of unrelated organisms who are from a different recent common ancestor. This group lacks a most recent common ancestor.

21. Clades are derived by using *shared derived characters*. What are these? (p.496)

Shared derived characters are evolutionary novelty (*physical characteristic, trait or feature*) unique to a particular clade.

22. Explain why for mammals, hair is a shared derived character, but a backbone is not. (p.496)

For mammals, hair is a shared derived character, but a backbone is not because a backbone is a novelty or feature common to all animals with backbones where hair is a novelty or feature unique to ONLY mammals.

23. Explain the principle of *parisomy*. (p.499)

The principal of parisomy states that a theory about nature should be the simplest explanation that is consistent with the facts.

24. Who was **William of Occam** and how does “*Occam’s Razor*” relate to the principle of parisomy. (p.499)

William of Occam was a 14th Century English Philosopher who is held to have advocated the minimalistic approach to problem solving or KEPPING IT SIMPLE.

25. How does “*Occam’s Razor*” apply to the construction of phylogenic trees? (p.499)

As applied to phylogenic trees, Occam's Razor means that a tree requiring the smallest number of evolutionary changes is the one you should assume is correct.

Let’s summarize some important information before you start the last section. The rate of evolution of DNA sequences varies from one part of the genome to another; therefore, comparing different sequences helps us to investigate relationships between groups of organisms that diverged a long time ago. For example, DNA that codes for *ribosomal RNA (rRNA)* changes relatively slowly and is useful for investigating relationships between taxa that diverged hundreds of millions of years ago. DNA that codes for *mitochondrial DNA (mtDNA)* evolves rapidly and can be used to explore recent evolutionary events.

26. Which method reveals that the Pima of Arizona and Yanomami of Venezuela are descendants of the same Native Americans that crossed the Bering Land Bridge 13,000 years ago? (p.495)

27. What are *molecular clocks*? (p.503)

Molecular clocks are evolutionary timing methods based on the observation that at least some regions of genomes evolve at constant rates.

28. Through the use of *molecular clocks*, approximately when did HIV emerge? (p.495)

HIV emerged sometime in the 1930s.

29. CLADOGRAM ACTIVITY

As defined in question 15, a **cladogram** is a diagram that depicts evolutionary relationships among groups. It is based on **PHYLOGENY**, which is the study of evolutionary relationships. Sometimes a cladogram is called a phylogenetic tree (*though technically, there are minor differences between the two*). In the past, biologists would group organisms based solely on their physical appearance. Today, with the advances in genetics and biochemistry, biologists can look more closely at individuals to discover their pattern of evolution, and group them accordingly - this strategy is called **EVOLUTIONARY CLASSIFICATION**.

CLADISTICS is form of analysis that looks at features of organisms that are considered "innovations", or newer features that serve some kind of purpose. (*Think about what the word "innovation" means in regular language.*) These characteristics appear in later organisms but not earlier ones and are called **DERIVED CHARACTERS**.

Examine the sample cladogram below, each letter on the diagram points to a derived character, or something different (newer) than what was seen in previous groups. Determine the character for each letter.

Note: this cladogram was created for simplicity and understanding, it does not represent the established phylogeny for insects.

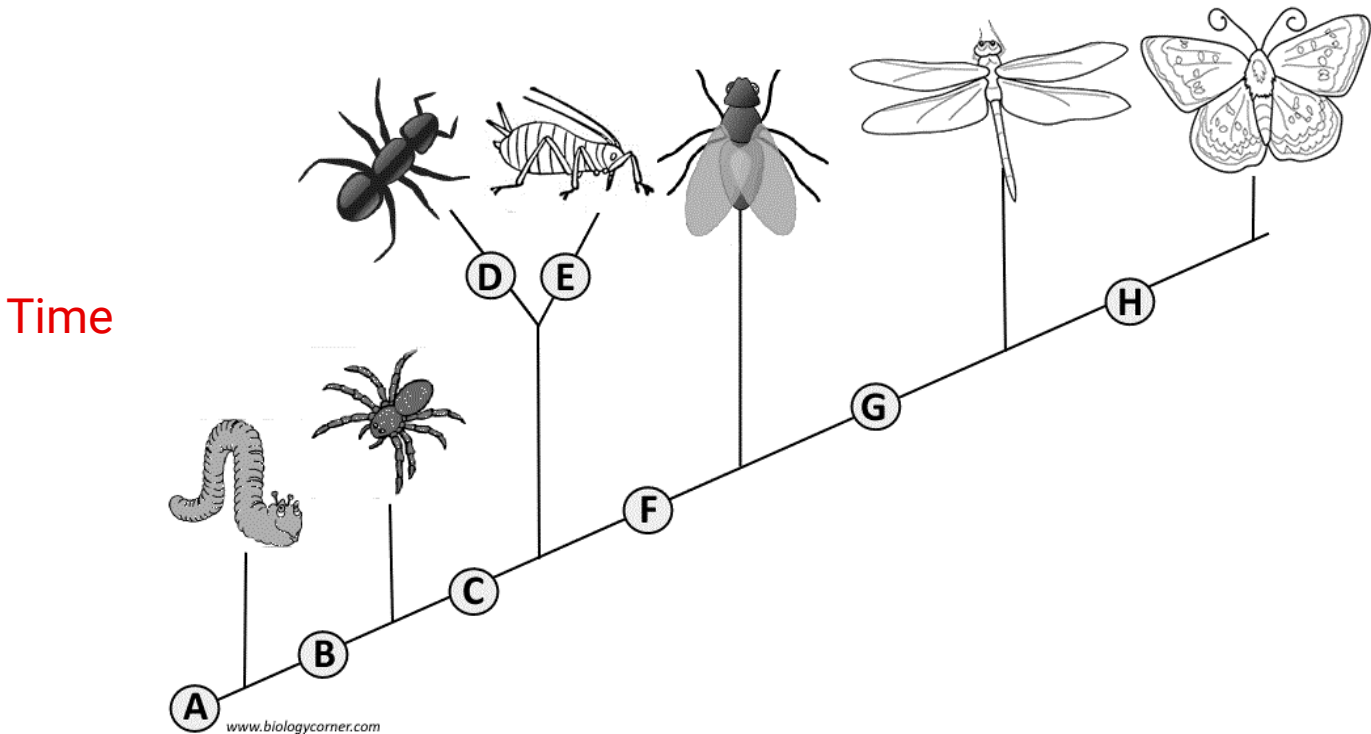

- (A) segmented bodies
- (B) legs
- (C) 6 legs
- (D) crushing mouth parts

- (E) abdominal appendages
- (F) wings
- (G) 2 sets of wings
- (H) curly antennae

30. To make a cladogram, you must first look at the animals you are studying and establish characteristics that they share and ones that are unique to each group. Based on that chart, create a cladogram like the one on the previous page.

Traits: Organism	Jaws	Lungs	Amniotic membrane	Hair	No tail	Bipedal
Lamprey	0	0	0	0	0	0
Shark	1	0	0	0	0	0
Salamander	1	1	0	0	0	0
Lizard	1	1	1	0	0	0
Tiger	1	1	1	1	0	0
Gorilla	1	1	1	1	1	0
Human	1	1	1	1	1	1

DRAWING OF YOUR CLADOGRAM:

